

Name \_\_\_\_\_

# Minnesota Comprehensive Assessments-Series III

Mathematics Item Sampler  
Grade 5



ITEM SAMPLERS ARE NOT SECURE TEST MATERIALS. THIS ITEM  
SAMPLER TEST BOOK MAY BE COPIED OR DUPLICATED.



## Grade 5 Formula Sheet

You may use the following formulas to solve problems on this test.

Formulas	Variables
$A = b \times h$ $A = \frac{1}{2} \times b \times h$	$A =$ area $b =$ base $h =$ height



## Mathematics Test General Directions

- This test contains two segments.
- You may write in this test book as scratch paper. Grid paper is also provided at the back of the test book.
- You will find a formula sheet at the beginning of this test book. You may tear it out of your test book to use while taking the test.
- For each question, choose the answer you think is best.
- Look at the sample questions that show how the different types of questions should be answered.

### Multiple-choice Question Answered in Test Book:

$$20 - 8 =$$

- A. 8
- B. 10
- C. 12
- D. 16

- Answer each fill in the blank question by writing your answer in the space below the question. You may only use the digits 0–9 and the symbols for fraction (/) and decimal (.). Do not include a label on your answer. If your answer is a mixed number you must change it to an improper fraction or a decimal.

### Fill in the Blank Question Answered in Test Book:

$$\frac{1}{4} + 1\frac{1}{4} = 6/4$$

- You **may not** use a calculator for Segment 1.
- You **may** use a calculator for Segment 2.
- When you finish a segment of the test, stop and check your answers. Then use the sticker given to you to seal it. Once you seal a segment, you cannot go back to it. Each segment must be sealed before you move on to the next segment.



On this test, do your own best work to show what you know and can do.

- Do not accept help finding answers to test questions.
- Do not give answers to other students.
- Do not tell others what is on the test.
- There may be consequences if you do not follow directions or if you behave dishonestly.

## Segment 1

You will be told when to begin this segment.

You **MAY NOT** use a calculator for this segment.





1. Divide.

$$2,564 \div 8$$

- A. 32 r4
- B. 308
- C.  $320\frac{1}{5}$
- D. 320.5

---

2. Which number has a 5 in the ten thousandths place?

- A. 0.20815
- B. 0.30256
- C. 0.40571
- D. 0.50098





3. Johan's race time was 45.03 seconds. Kyle's race time was 0.1 second less than Johan's time. What was Kyle's race time?
- A. 44.03 seconds
  - B. 44.93 seconds
  - C. 45.13 seconds
  - D. 45.14 seconds
- 

4. What is 0.45831 rounded to the nearest thousandth?
- A. 0.45
  - B. 0.458
  - C. 0.459
  - D. 0.4583
- 

5. Add.

$$45.908 + 3.26$$

- A. 46.234
- B. 49.168
- C. 49.24
- D. 78.508



1

6. A fraction model is shown.

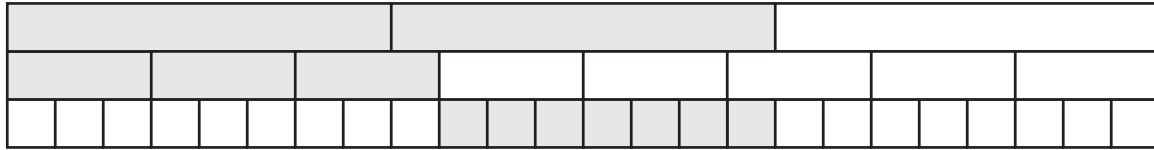

What is represented by the model?

- A.  $\frac{2}{1} - \frac{3}{5}$
- B.  $\frac{2}{3} - \frac{3}{8}$
- C.  $\frac{2}{3} - \frac{1}{5}$
- D.  $\frac{3}{8} - \frac{7}{24}$
- 
7. Yesterday, Jamal read 17 pages in his book. Today, he read more pages than he read yesterday. Which inequality shows  $p$ , the number of pages Jamal could have read today?
- A.  $p < 17$
- B.  $p \leq 17$
- C.  $p > 17$
- D.  $p \geq 17$



8. How many edges does a hexagonal prism have?

- A. 6
- B. 8
- C. 12
- D. 18

Put sticker  
here

**This is the end of Segment 1.**  
Check your work. Then seal this segment.



Put sticker  
here

## Segment 2

You will be told when to begin this segment.

You **MAY** use a calculator for this segment.

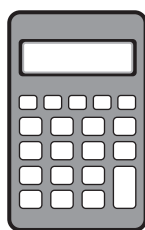



## Mathematics Test — Segment 2

9. Jan has 500 pieces of paper. She prints as many copies as possible of a 16-page report. How many pieces of paper are left?
- A. 4
  - B. 9
  - C. 25
  - D. 31

2

- 
10. A bookcase has 4 shelves. The bottom shelf has 10 books. Each of the other shelves has 5 more books than the shelf below it. How many books are in the bookcase?
- A. 25
  - B. 40
  - C. 55
  - D. 70



11. Five points are shown on a number line.

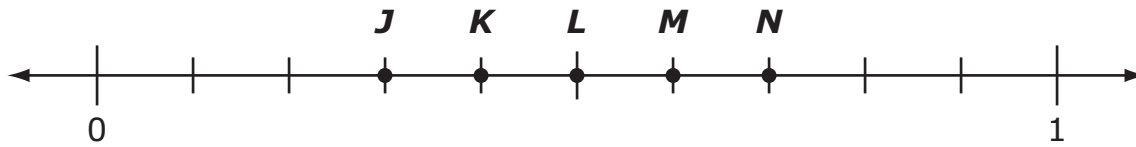

Between which 2 points is  $\frac{7}{16}$  located?

- A. *J* and *K*
- B. *K* and *L*
- C. *L* and *M*
- D. *M* and *N*

2

---

12. Lydia used  $\frac{1}{25}$  of her notebook paper. What decimal amount did she use?

- A. 0.04
- B. 0.4
- C. 1.25
- D. 2.5



13. Jill is  $48\frac{5}{8}$  inches tall. Lei is 47.5 inches tall. What is the difference in their heights?
- A. 0.125 inches
  - B. 1.08 inches
  - C. 1.125 inches
  - D. 1.62 inches

2

14. At a movie store, Erin pays a monthly fee and is charged for each movie she rents. The table shows the monthly cost when Erin rents different numbers of movies.

**Monthly Cost**

<b>Number of Movies</b>	<b>Total Cost (dollars)</b>
6	33
8	39
10	45

How much is the monthly fee that Erin pays?

- A. \$3
- B. \$6
- C. \$15
- D. \$18





15. Three points are shown on a grid.

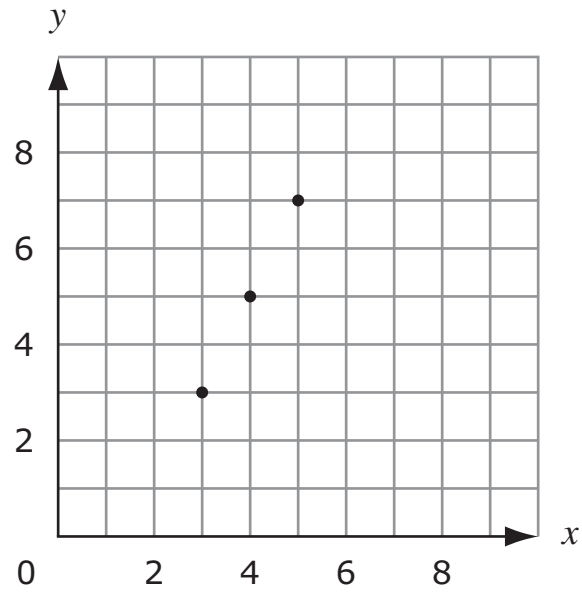

Which rule was used to plot the points?

- A.  $y = x$
- B.  $y = x + 2$
- C.  $y = \frac{1}{2}x + 3$
- D.  $y = 2x - 3$



**16.** An expression is shown.

$$4 + 3(6 + 10) \div 2$$

What is the value of the expression?

- A.** 16
- B.** 26
- C.** 28
- D.** 56

2

---

**17.** Which value makes the equation  $5b + 15 = 30$  true?

- A.**  $b = 3$
- B.**  $b = 9$
- C.**  $b = 10$
- D.**  $b = 75$



18. What is the value of  $4k + 6(j - 2)$  when  $k = 3$  and  $j = 5$ ?
- A. 26
  - B. 30
  - C. 40
  - D. 108

---

**Please write your answer in the space below the question. You may use the digits: 0-9 and the symbols: slash for a fraction bar (/) and a decimal (.). If your answer is a mixed number you must change it to an improper fraction or a decimal.**

19. A triangle has a height of 25 feet. The length of its base is 12 feet. What is the area of the triangle?



20. Which net makes a cylinder?

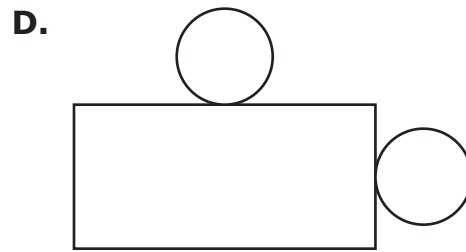
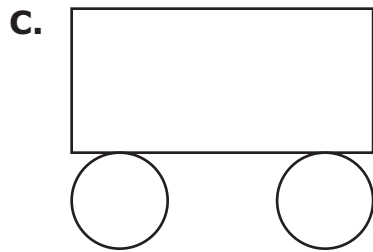
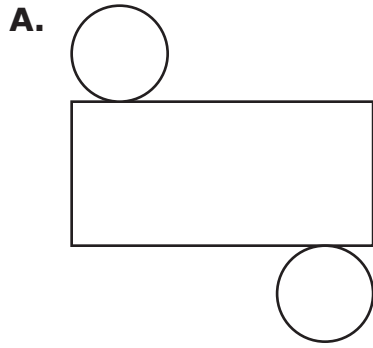

2



21. A trapezoid is shown.

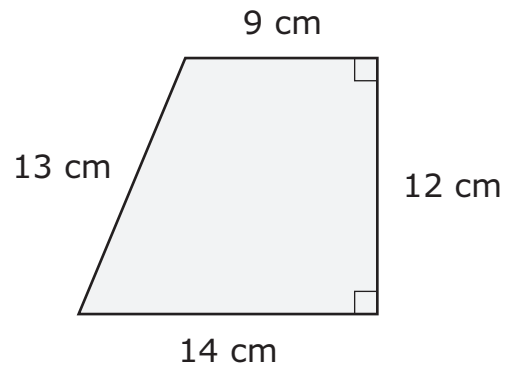

What is the area of the trapezoid?

- A.  $48 \text{ cm}^2$
- B.  $138 \text{ cm}^2$
- C.  $168 \text{ cm}^2$
- D.  $173 \text{ cm}^2$



22. Amy covers the box shown with paper.

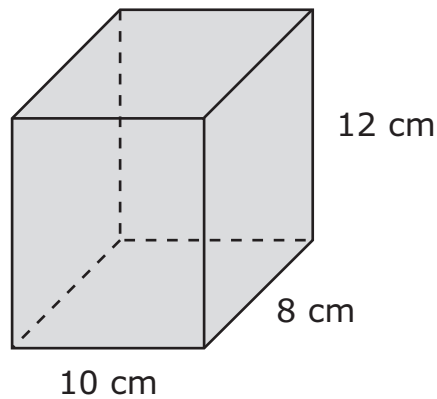

2

What is the surface area of the box?

- A. 180 sq. cm
- B. 296 sq. cm
- C. 592 sq. cm
- D. 960 sq. cm

---

23. A rectangular prism has a height of  $h$  cm. The area of its base is  $B$  cm<sup>2</sup>. How much does the volume of the prism increase when the height is increased by 1 cm?

- A.  $1 \text{ cm}^3$
- B.  $h+1 \text{ cm}^3$
- C.  $B \text{ cm}^3$
- D.  $B+1 \text{ cm}^3$



24. Anya listed the prices of meals on a menu.

\$14.85 \$10.75 \$8.50 \$12.45 \$9.20

What is the mean price of the meals?

- A. \$6.35
- B. \$8.50
- C. \$10.75
- D. \$11.15

25. Maria recorded the heights of 2 plants for 4 weeks.

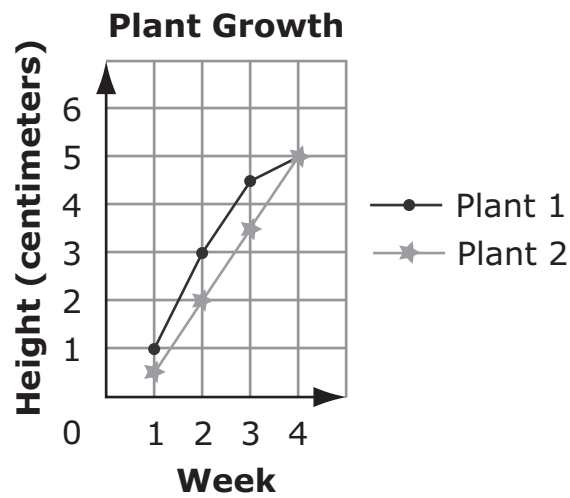

How much did plant 2 grow from week 1 to week 2?

- A. 1 cm
- B.  $1\frac{1}{2}$  cm
- C. 2 cm
- D.  $4\frac{1}{2}$  cm

Put sticker  
here

**This is the end of Segment 2.**  
Check your work. Then seal this segment.





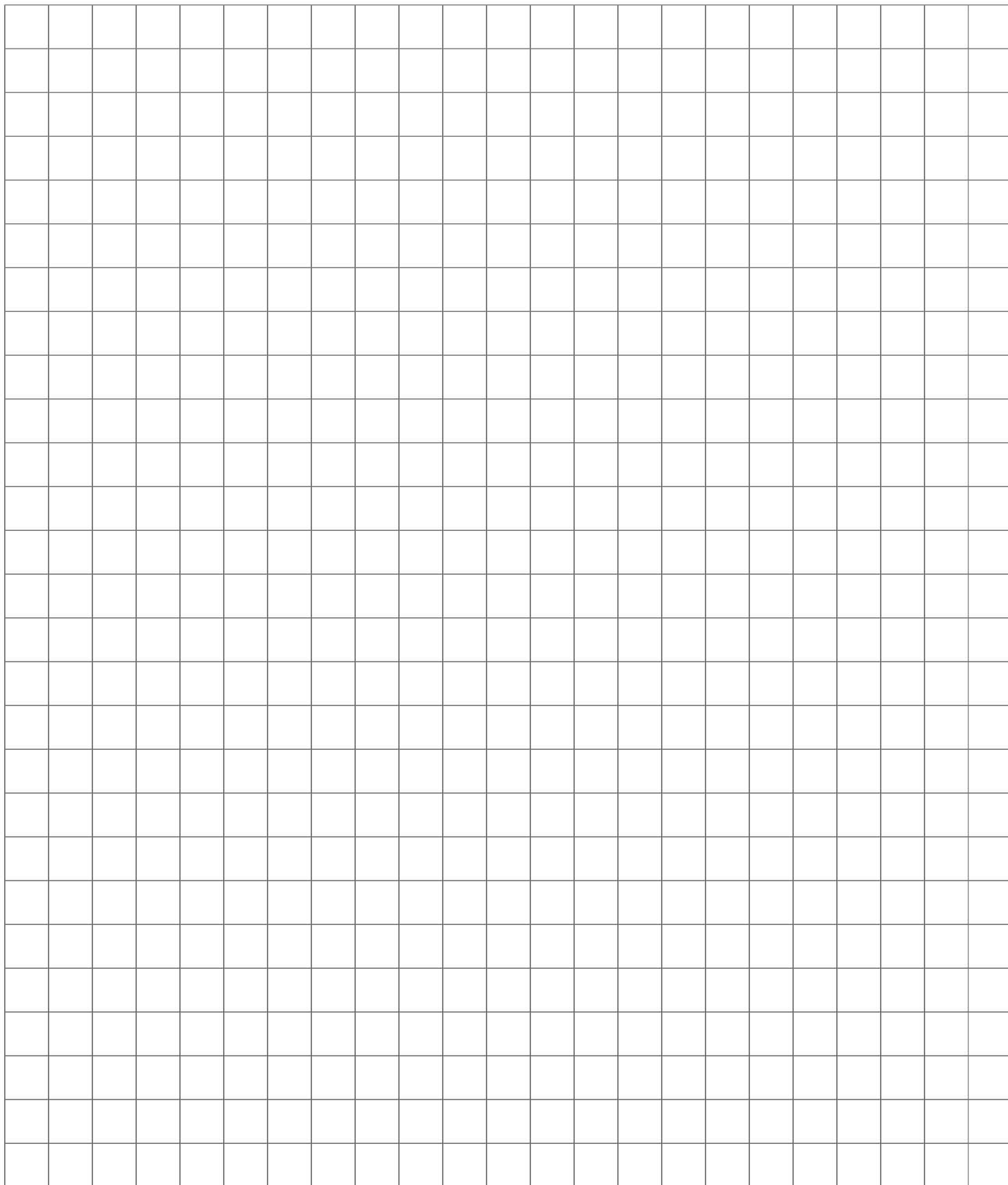

**ITEM SAMPLERS ARE NOT SECURE TEST MATERIALS. THIS ITEM  
SAMPLER TEST BOOK MAY BE COPIED OR DUPLICATED.**