

Name _____

Minnesota Comprehensive Assessments-Series III

Mathematics Item Sampler
Grade 4



**ITEM SAMPLERS ARE NOT SECURE TEST MATERIALS.
THIS ITEM SAMPLER TEST BOOK MAY BE COPIED
OR DUPLICATED.**

Mathematics Test

General Directions

- This test contains four segments.
- You may write in this test book as scratch paper. Grid paper is also provided at the back of the test book.
- For each question, choose the answer you think is best.
- Look at the sample that shows how to answer the question.

Sample Question Answered in Test Book:

$$20 - 8 =$$

A. 8

B. 10

C. 12

D. 16

- You **may not** use a calculator for Segment 1.
- You **may** use a calculator for Segments 2, 3, and 4.
- When you finish a segment of the test, stop and check your answers. Then use the sticker given to you to seal it. Once you seal a segment, you cannot go back to it. Each segment must be sealed before you move on to the next segment.

The General Direction page is the same as it appears in the test. The item sampler will only have 2 segments. You may use a calculator for Segment 2.

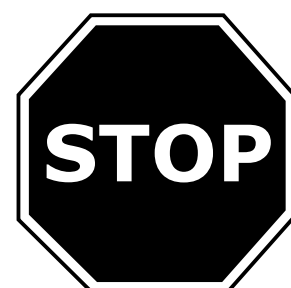

On this test, do your own best work to show what you know and can do.

- Do not accept help finding answers to test questions.
- Do not give answers to other students.
- Do not tell others what is on the test.
- There may be consequences if you do not follow directions or if you behave dishonestly.

Segment 1

You will be told when to begin this segment.

You **MAY NOT** use a calculator for this segment.





Mathematics Test — Segment 1

- 1.** There are 35 students going on a class trip. The students ride in vans. There are 7 students riding in each van. How many vans are needed to take all the students?
- A.** 4
B. 5
C. 6
D. 7
-
- 2.** A truck has 50 boxes of jump ropes. Each box contains 100 jump ropes. How many jump ropes are on the truck?
- A.** 50
B. 500
C. 5,000
D. 50,000



3. Two numbers are multiplied together.

$$\begin{array}{r} 724 \\ \times 8\boxed{} \\ \hline 62,264 \end{array}$$

Which digit goes in the box?

- A. 0
 - B. 1
 - C. 4
 - D. 6
-

4. Divide.

$$908 \div 4$$

- A. 202
- B. 212
- C. 227
- D. 247



5. What is 9.582 rounded to the nearest tenth?
- A. 9.5
 - B. 9.58
 - C. 9.6
 - D. 10
-

6. Robert has 54 pencils. He has 1 box of pencils and 3 packages of pencils. The box has 24 pencils. Which equation can be used to find p , the number of pencils in each package?
- A. $p = 54 + 3 \times 24$
 - B. $24 = 54 + 3 \times p$
 - C. $54 = 3 + 24 \times p$
 - D. $54 = 24 + 3 \times p$



7. A figure is shown.

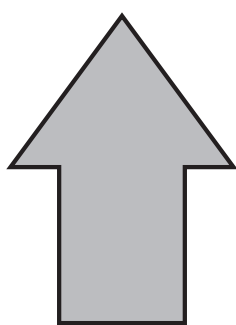

Which shows a 90° counterclockwise rotation of the figure?

A.

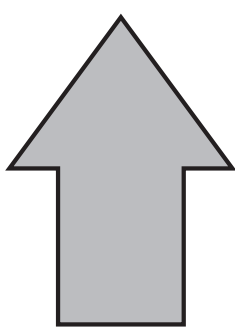

B.

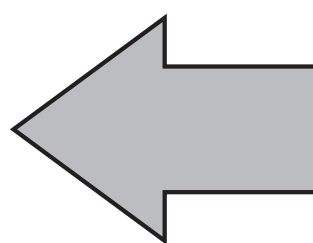

C.

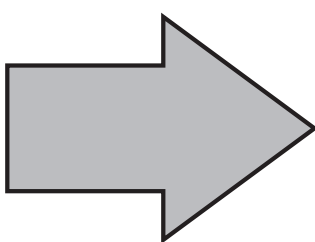

D.

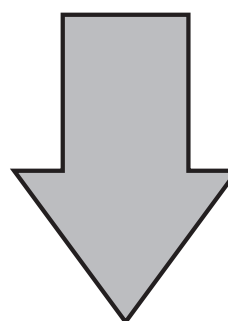

Put sticker
here



This is the end of Segment 1.
Check your work. Then seal this segment.



Segment 2

You will be told when to begin this segment.

You **MAY** use a calculator for this segment.

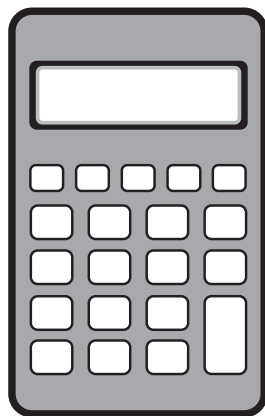

Put sticker
here



Mathematics Test — Segment 2

8. A fraction model is shown.

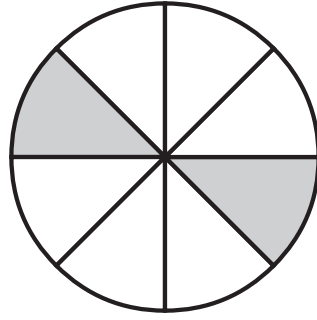

Which shows an equivalent fraction?

2

A.

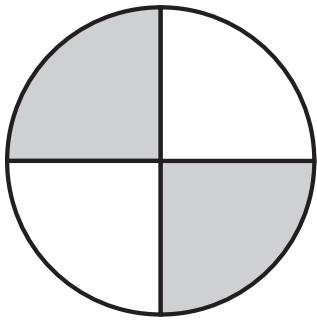

B.

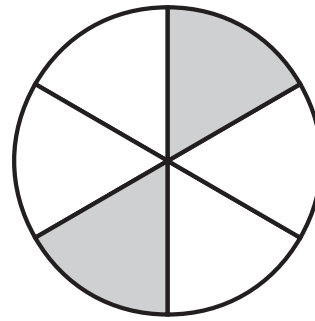

C.

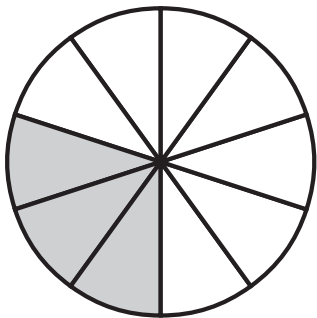

D.

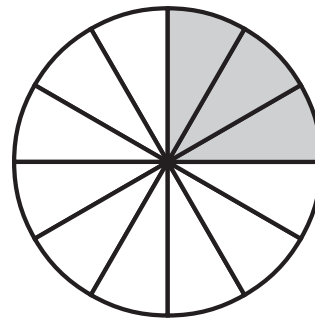

ITEM SAMPLER
MAY BE DUPLICATED.

Go on to the next page.



9. Which point is shown at $\frac{2}{3}$?

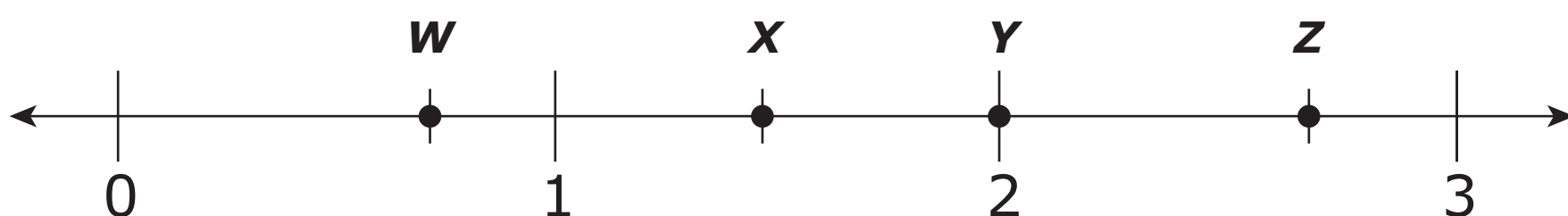

- A. W
- B. X
- C. Y
- D. Z

2

-
10. In the number 200.358, which digit is in the hundredths place?

- A. 2
- B. 3
- C. 5
- D. 8

ITEM SAMPLER
MAY BE DUPLICATED.

Go on to the next page.



11. Which shape is a rhombus?

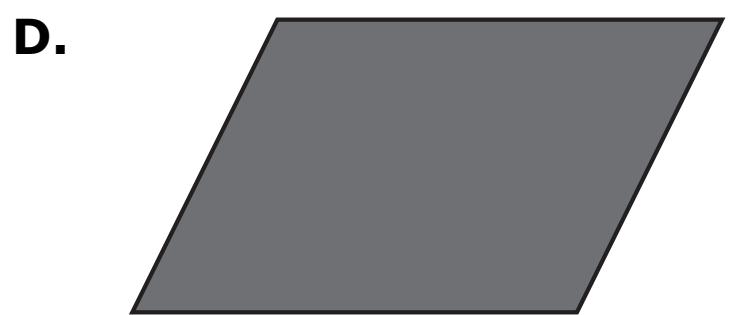
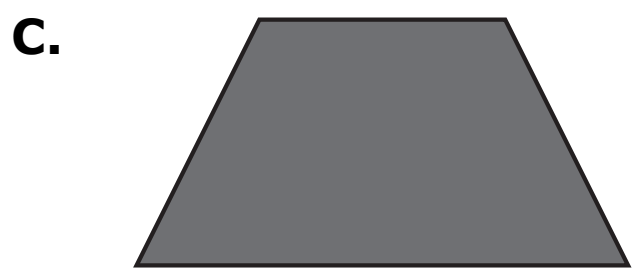
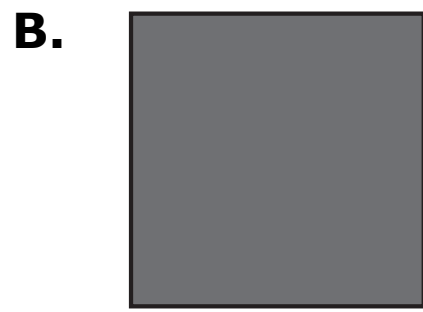

2

12. An angle is shown.

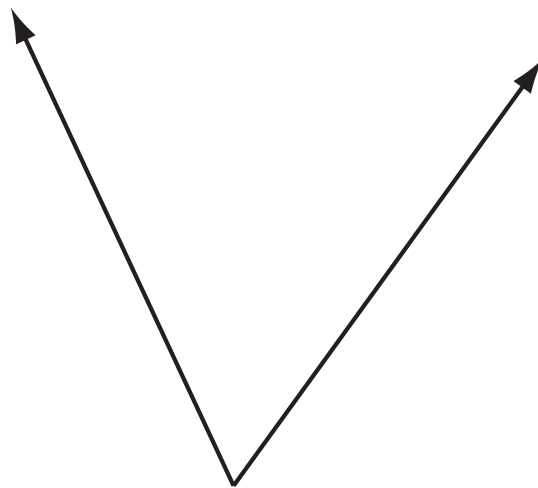

Which describes the angle?

- A.** Acute
- B.** Obtuse
- C.** Right
- D.** Straight

**ITEM SAMPLER
MAY BE DUPLICATED.**

Go on to the next page.



13. The shape of a floor is shown.

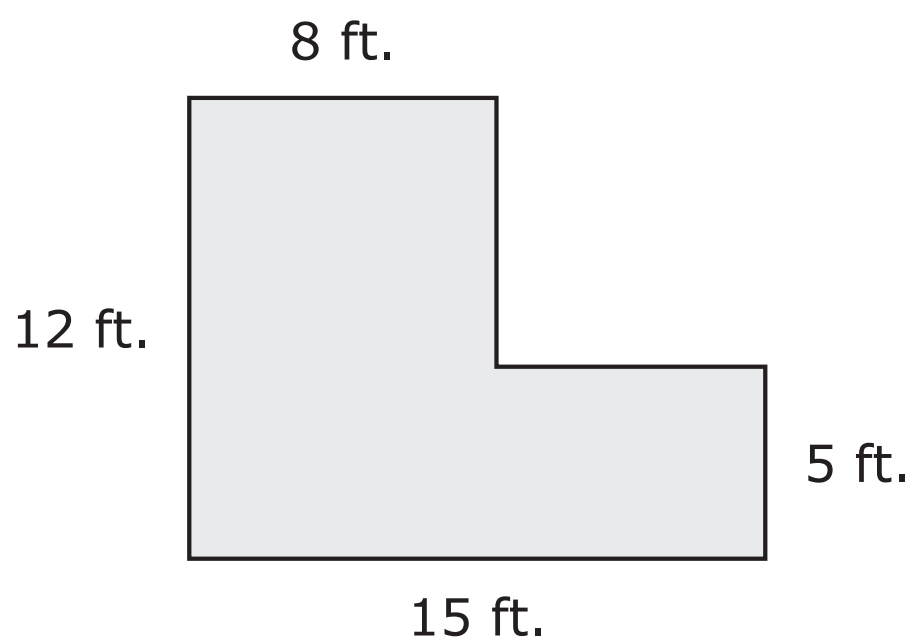

What is the area of the floor?

- A.** 40 sq. ft.
- B.** 131 sq. ft.
- C.** 171 sq. ft.
- D.** 180 sq. ft.

2



14. A shape is shown.

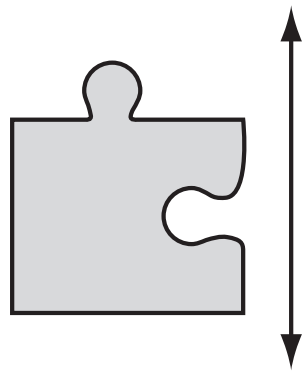

Which shows a translation of the shape over the line?

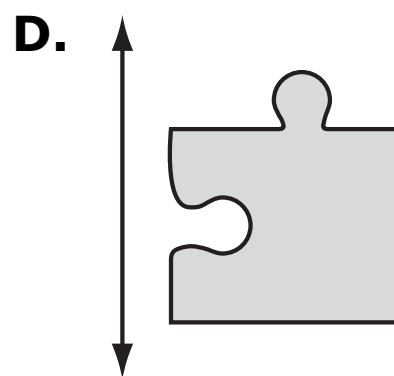
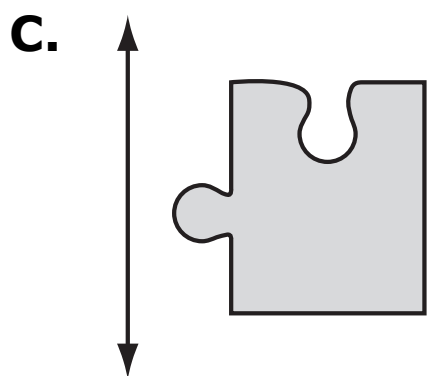
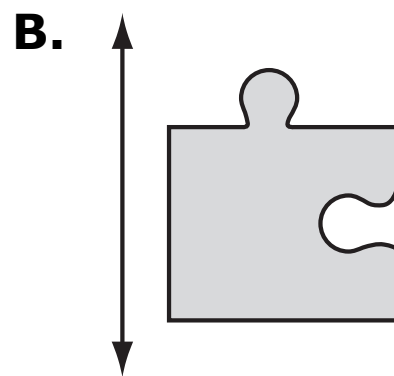
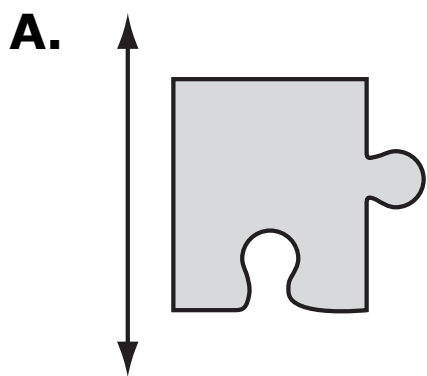

**ITEM SAMPLER
MAY BE DUPLICATED.**

Go on to the next page.



15. A student creates a timeline for a history project. Which shows a timeline?

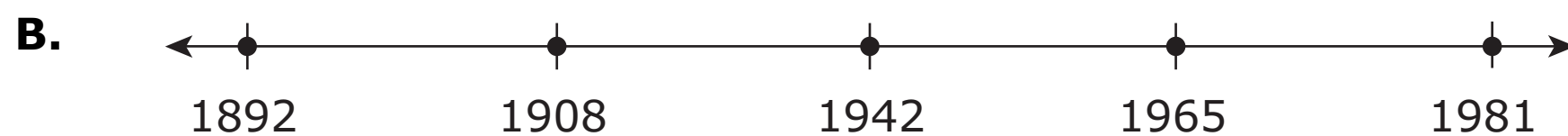
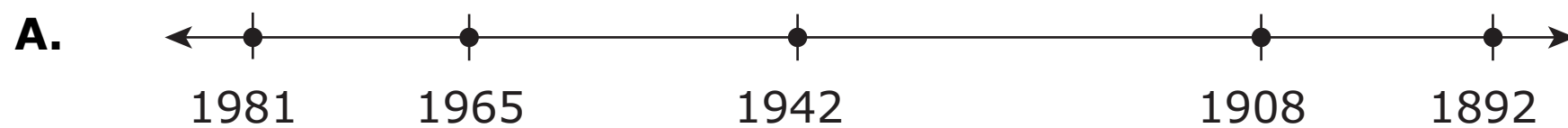

2

16. A camping group bought 15 sleeping bags that cost \$42 each and a tent that cost \$160. What was the total cost of the sleeping bags and the tent?

- A.** \$217
- B.** \$630
- C.** \$790
- D.** \$2,442

**ITEM SAMPLER
MAY BE DUPLICATED.**

Go on to the next page.



17. Jason has 8 cupcakes.

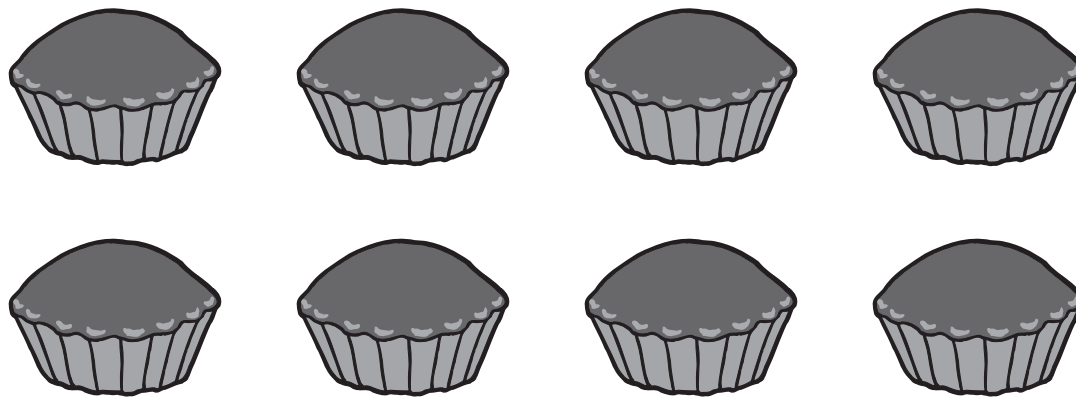

2 He eats $\frac{1}{8}$ of the cupcakes and gives $\frac{2}{8}$ of the cupcakes to his friends. What fraction of the cupcakes are left?

- A. $\frac{1}{8}$
- B. $\frac{3}{8}$
- C. $\frac{5}{8}$
- D. $\frac{3}{5}$



- 18.** A decimal number is shown on a grid.

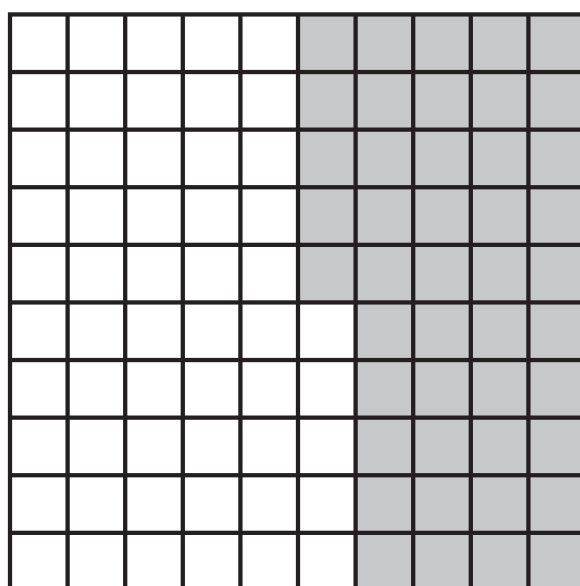

Which number is less than the number shown on the grid?

- A.** 0.9
- B.** 0.48
- C.** 0.450
- D.** 0.275

2

-
- 19.** Which fraction is equivalent to 0.23?

- A.** $\frac{1}{23}$
- B.** $\frac{23}{10}$
- C.** $\frac{23}{100}$
- D.** $\frac{2}{3}$

**ITEM SAMPLER
MAY BE DUPLICATED.**

Go on to the next page.



20. A table is shown.

<i>f</i>	<i>g</i>
4	2
8	4
16	8

What rule was used to make the table?

- A.** $g = 2f$
- B.** $g = \frac{f}{2}$
- C.** $g = f + 2$
- D.** $g = 2f + 2$

2



21. An equation is shown.

$$12 \text{ _____ } 5 = 17 + 43$$

Which symbol makes the equation true?

- A.** +
- B.** -
- C.** ×
- D.** ÷

22. Which statement is true about an obtuse triangle?

- A.** It has 2 acute angles.
- B.** It has 2 obtuse angles.
- C.** It can be a right triangle.
- D.** It can be an acute triangle.



23. Which shows a line of symmetry?

A.

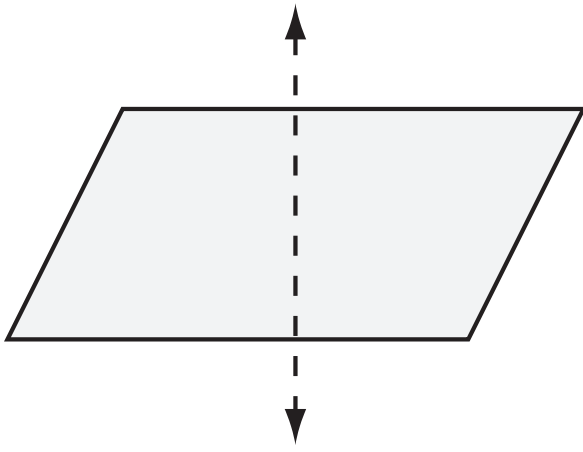

B.

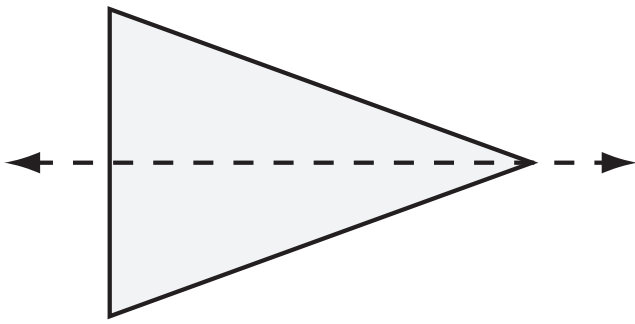

C.

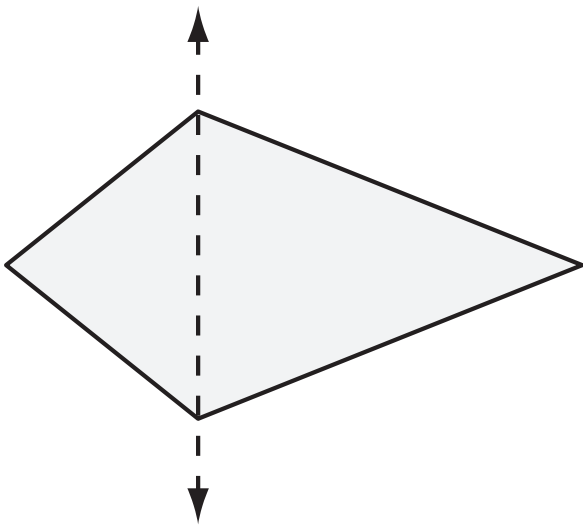

D.

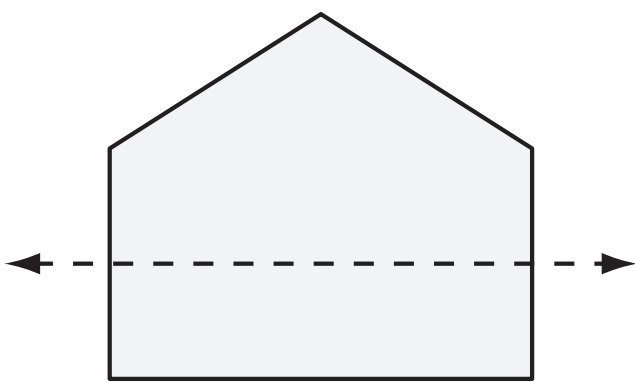

2

ITEM SAMPLER
MAY BE DUPLICATED.

Go on to the next page.



- 24.** Kira is using 1-inch square tiles to cover a table top. The table top is 24 inches long and 18 inches wide. She lays the tiles into strips of 6.



How many strips of tiles will Kira need to cover the table with no gaps or overlaps?

- A.** 14
- B.** 18
- C.** 72
- D.** 432

-
- 25.** Ron draws a trapezoid, then rotates it 90° .

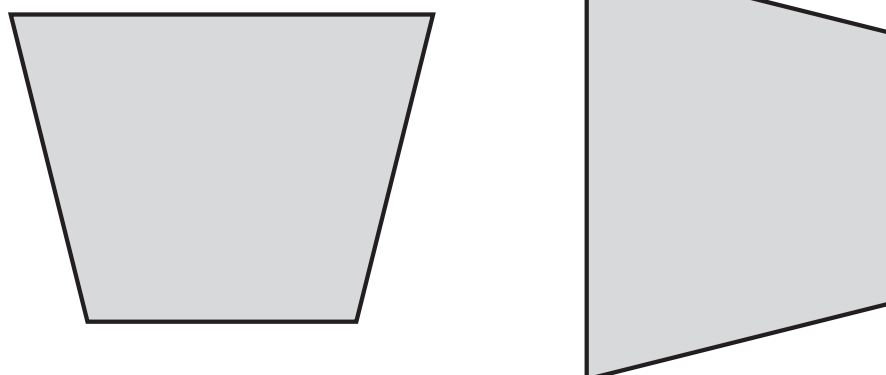

Which statement is true about the 2 trapezoids?

- A.** They are congruent because all trapezoids are congruent.
- B.** They are congruent because rotating a trapezoid does not change its size and shape.
- C.** They are not congruent because rotating the trapezoid changes its side lengths.
- D.** They are not congruent because rotating the trapezoid changes its angle measures.

Put sticker
here



This is the end of Segment 2.
Check your work. Then seal this segment.



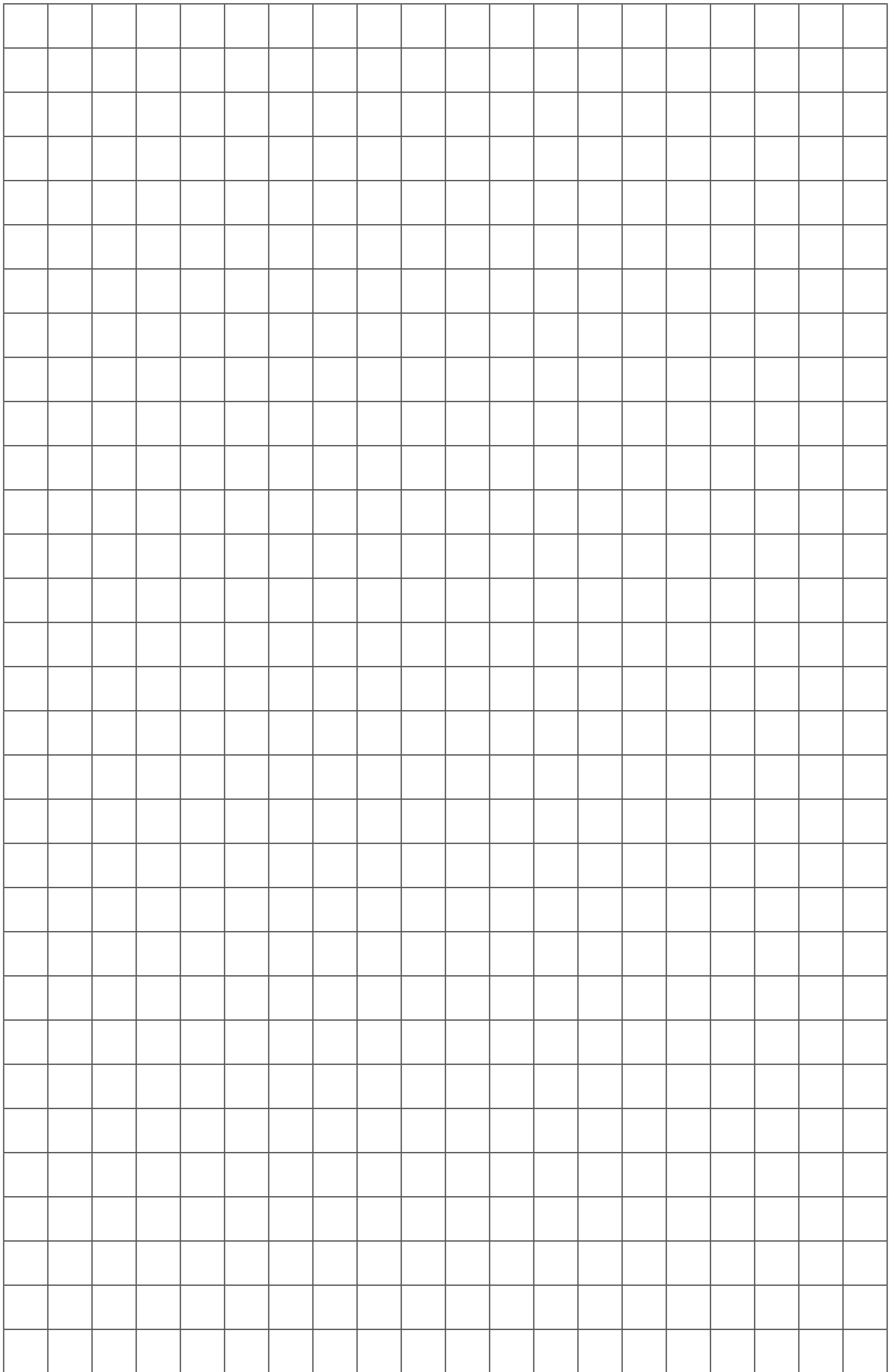

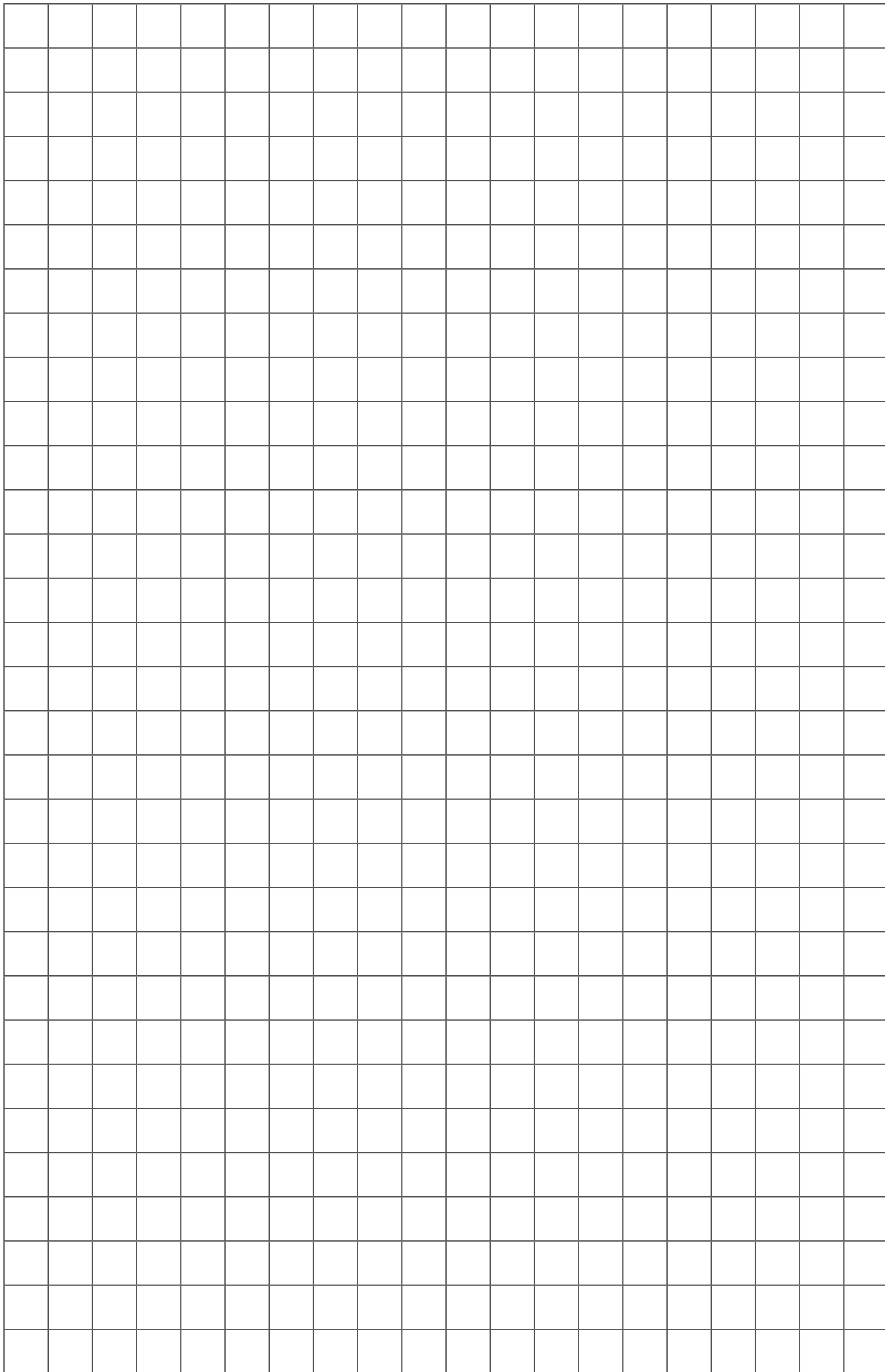

**ITEM SAMPLERS ARE NOT SECURE TEST MATERIALS.
THIS ITEM SAMPLER TEST BOOK MAY BE COPIED
OR DUPLICATED.**

**Grade 4
Mathematics Item Sampler
18pt**